

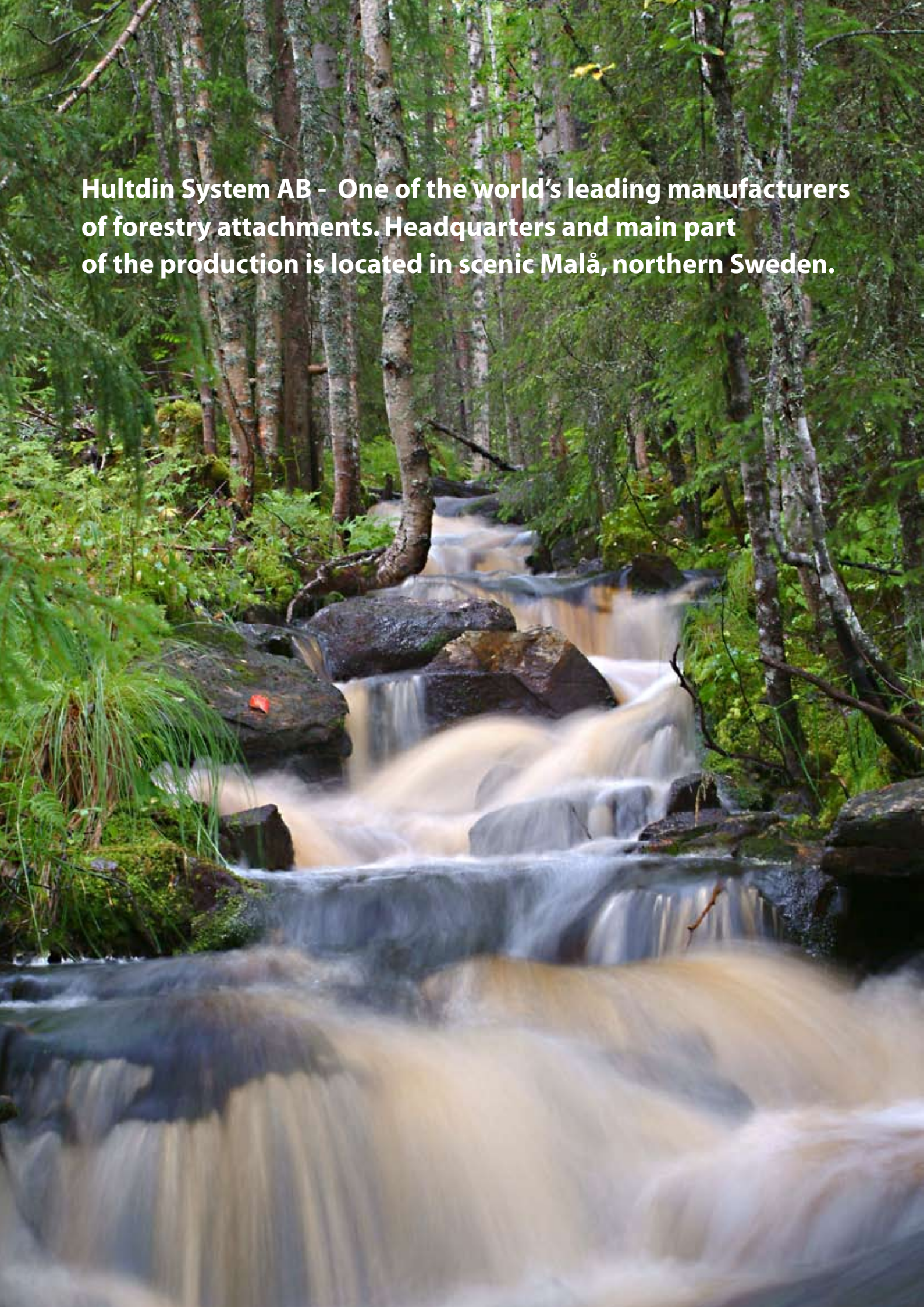

HULTDINS
SuperGrip™

Hultdin System AB - One of the world's leading manufacturers of forestry attachments. Headquarters and main part of the production is located in scenic Malå, northern Sweden.





Hultdins SuperGrip is the best selling professional timber grapple in the world. No matter if it is on a forwarder, self loader or excavator, in desert heat or freezing cold, on a sunny day or in pouring rain. Every hour of the day, every day of the year, tens of thousands of Hultdins grapples are handling various logs in all corners of the globe.

This is not a mere coincidence.

Hultdins has developed and produced forestry grapples for almost 50 years. Big efforts are put in trying to offer the best products for our customers at a reasonable cost. We know that in the end it is only when our customer reaches a higher productivity and product lifetime than someone who is working with another grapple, that we can feel safe.

Thank you for choosing a grapple from Hultdins!

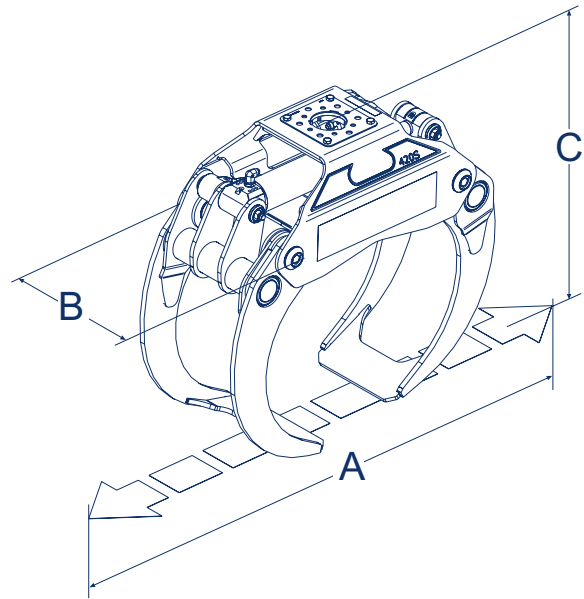

SuperGrip II

Features

- Optimized design that secures high quality and strength
- Tapered sleeve pin design eliminates any joint motion
- Strong cushioned cylinder reduces shock loads, designed for up to 25 MPa working pressure
- High strength steel and robotized welding ensures minimized down time
- Grapple saw option available on all models

SuperGrip II		260	300	360	420	520
Weight	kg	184	190	298	328	364
Max. load	kg	3 500	3 500	5 000	5 000	7 000
Gripping area, tip-tip	m ²	0.26	0.30	0.36	0.42	0.52
Gripping area, practical	m ²	0.35	0.40	0.45	0.52	0.65
Max. gripping width "A"	mm	1 547	1 526	1 886	2 075	2 129
Overall grapple width "B"	mm	460	460	548	548	548
Height, arms tip-tip "C"	mm	878	915	980	1 061	1 155
Max. height arms open	mm	743	790	808	851	965
Min. height arms closed	mm	575	560	640	697	696
Grapple jaw width	mm	380	380	460	460	460
Min. gripping diameter	mm	110	110	150	180	170
Gripping force, arms open, at 25 MPa	kN	12.0	12.0	19.0	20.2	18.2
Gripping force, arms tip-tip, at 25 MPa	kN	14.3	14.3	19.0	24.3	21.9
Opening time, at 50 l/min	s	1.0	0.91	1.8	2.6	2.6
Closing time, at 50 l/min	s	1.7	1.7	2.5	3.5	3.5
Max. operating pressure	MPa	25	25	25	25	25

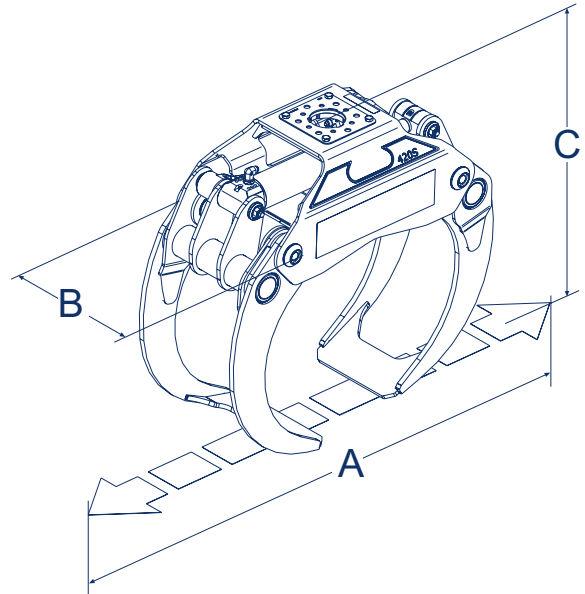

SuperGrip II -S

Features

- A reinforced model for the tougher applications
- Tapered sleeve pin design eliminates any joint motion
- Strong cushioned cylinder reduces shock loads, designed for up to 25 MPa working pressure
- High strength steel and robotized welding ensures minimized down time
- Grapple saw option available on all models

SuperGrip II		260S	300S	360S	420S
Weight	kg	200	205	326	370
Max. load	kg	3 500	3 500	6 000	7 000
Gripping area, tip-tip	m ²	0.26	0.30	0.36	0.42
Gripping area, practical	m ²	0.35	0.40	0.45	0.52
Max. gripping width "A"	mm	1 547	1 526	1 886	2 075
Overall grapple width "B"	mm	460	460	548	548
Height, arms tip-tip "C"	mm	878	915	980	1 061
Max. height arms open	mm	743	790	808	851
Min. height arms closed	mm	575	560	640	697
Grapple jaw width	mm	388	388	468	468
Min. gripping diameter	mm	110	110	150	180
Gripping force, arms open, at 25 MPa	kN	12.0	12.0	19.0	20.2
Gripping force, arms tip-tip, at 25 MPa	kN	14.3	14.3	19.0	24.3
Opening time, at 50 l/min	s	1.0	1.0	1.8	2.6
Closing time, at 50 l/min	s	1.7	1.7	2.5	3.5
Max. operating pressure	MPa	25	25	25	25

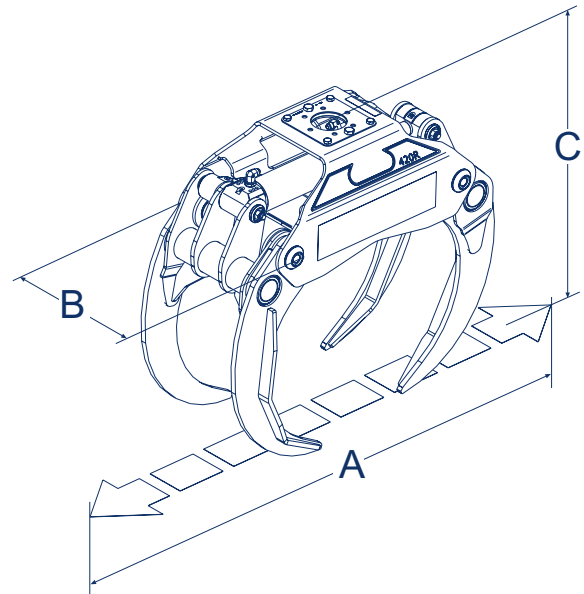

SuperGrip II -R

Features

- For handling of slash and bioenergy wood. (Note! Not suitable for stumps)
- Tapered sleeve pin design eliminates any joint motion
- Strong cushioned cylinder reduces shock loads, designed for up to 25 MPa working pressure
- High strength steel and robotized welding ensures minimized down time
- The R-model is based on the arms of the respective S-model

SuperGrip II		260R	300R	360R	420R
Weight	kg	198	204	316	345
Max. load	kg	3 000	3 000	4 000	4 000
Gripping area, tip-tip	m ²	0.26	0.30	0.36	0.42
Gripping area, practical	m ²	0.35	0.40	0.45	0.52
Max. gripping width "A"	mm	1 555	1 537	1 867	2 060
Overall grapple width "B"	mm	468	468	568	568
Height, arms tip-tip "C"	mm	855	886	939	1 043
Max. height arms open	mm	693	739	759	802
Min. height arms closed	mm	580	570	645	693
Grapple jaw width	mm	390	388	468	468
Min. gripping diameter	mm	110	110	146	180
Gripping force, arms open, at 25 MPa	kN	12.0	12.0	19.0	20.2
Gripping force, arms tip-tip, at 25 MPa	kN	14.3	14.3	19.0	24.3
Opening time, at 50 l/min	s	1.0	1.0	1.8	2.6
Closing time, at 50 l/min	s	1.7	1.7	2.5	3.5
Max. operating pressure	MPa	25	25	25	25

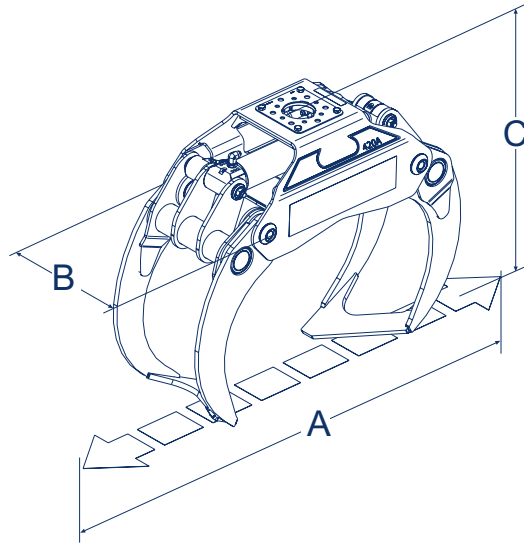

SuperGrip II -A

Features

- Unique arm geometry improves the selection and handling of individual logs
- Asymmetric grapple arm design improves the “rolling” of the logs into the grapple during the loading process
- The pointy grapple tip design minimizes the picking of unwanted debris
- The A-grapple works well in multiple applications from the handling of round wood to bio-mass applications

SuperGrip II		260A	300A	360A	420A
Weight	kg	200	205	326	370
Max. load	kg	3 500	3 500	5 000	5 500
Gripping area	m ²	0.26	0.30	0.36	0.42
Max. gripping width “A”	mm	1520	1485	1840	2 037
Overall gripping width “B”	mm	460	460	548	548
Height, arms tip-tip “C”	mm	945	975	1060	1129
Max. height arms open	mm	830	876	888	928
Min. height arms closed	mm	583	579	689	695
Grapple jaw width	mm	388	388	468	468
Min. gripping diameter	mm	110	110	150	180
Gripping force, arms open, at 25 MPa	kN	12.0	12.0	19.0	20.2
Gripping force, arms tip-tip, at 25 MPa	kN	14.3	14.3	19.0	24.3
Opening time, at 50 l/min	s	1.0	1.0	1.8	2.6
Closing time, at 50 l/min	s	1.7	1.7	2.5	3.5
Max. operating pressure	MPa	25	25	25	25

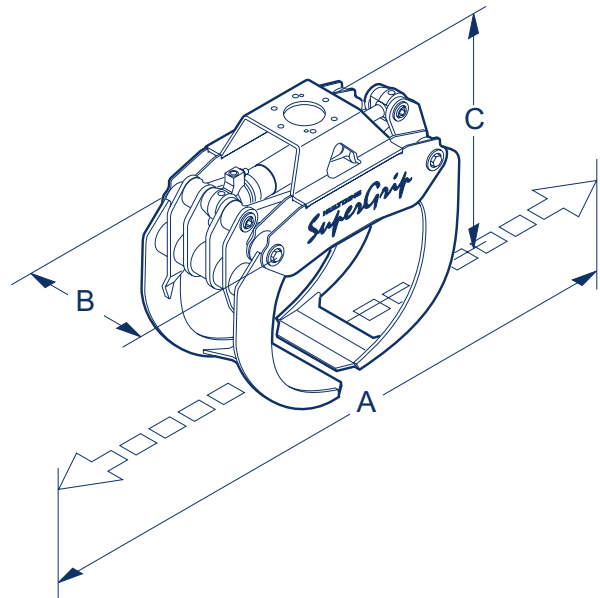

SuperGrip

Features

- Tapered sleeve pin design eliminates any joint motion
- Sealed bushings allow for 1000 hour greasing interval
- Strong cushioned cylinder reduces shock loads, designed for up to 25 MPa working pressure
- High strength steel and robotized welding ensures minimized down time
- Grapple saw option available on all models

SuperGrip		260	360	420	520
Weight	kg	180	288	320	350
Max. load	kg	3 500	5 000	5 000	5 500
Gripping area, tip-tip	m ²	0.26	0.36	0.42	0.52
Gripping area, practical	m ²	0.35	0.45	0.52	0.62
Max. gripping width "A"	mm	1 525	1 870	2 075	2 322
Overall grapple width "B"	mm	430	510	510	514
Height, arms tip-tip "C"	mm	867	962	1 040	1 155
Max. height arms open	mm	760	800	848	886
Min. height arms closed	mm	550	627	649	747
Grapple jaw width	mm	384	452	460	456
Min. gripping diameter	mm	90	110	120	170
Gripping force, arms open, at 25 MPa	kN	10.9	18.5	19.4	20.9
Gripping force, arms tip-tip, at 25 MPa	kN	15.1	19.2	20.0	23.1
Opening time, at 50 l/min	s	0.9	1.6	2.1	2.2
Closing time, at 50 l/min	s	1.7	2.6	3.5	3.7
Max. operating pressure	MPa	25	25	25	25

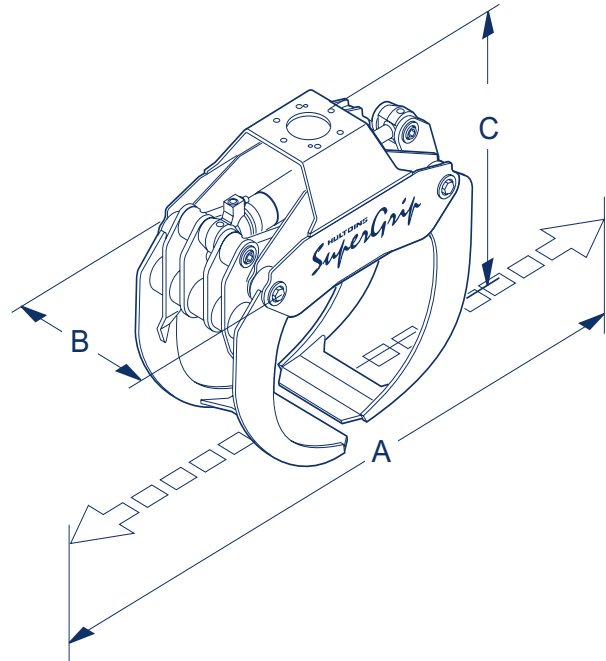

SuperGrip -S

Features

- Heavily reinforced model for the toughest jobs in the forest and excavator applications
- Tapered sleeve pin design eliminates any joint motion
- Sealed bushings allow for 1000 hour greasing interval
- Strong cushioned cylinder reduces shock loads, designed for up to 25 MPa working pressure
- Grapple saw option available on all models

SuperGrip		260S	360S	520S
Weight	kg	230	370	420
Max. load	kg	4 500	8 000	8 000
Gripping area, tip-tip	m ²	0.26	0.36	0.52
Gripping area, practical	m ²	0.35	0.45	0.62
Max. gripping width "A"	mm	1 525	1 870	2 322
Overall grapple width "B"	mm	430	522	514
Height, arms tip-tip "C"	mm	867	998	1 155
Max. height arms open	mm	760	800	886
Min. height arms closed	mm	550	656	747
Grapple jaw width	mm	384	460	484
Min. gripping diameter	mm	90	110	170
Gripping force, arms open, at 25 MPa	kN	10.9	18.5	20.9
Gripping force, arms tip-tip, at 25 MPa	kN	15.1	19.2	23.1
Opening time, at 50 l/min	s	0.9	1.6	2.2
Closing time, at 50 l/min	s	1.7	3.5	3.7
Max. operating pressure	MPa	25	25	25

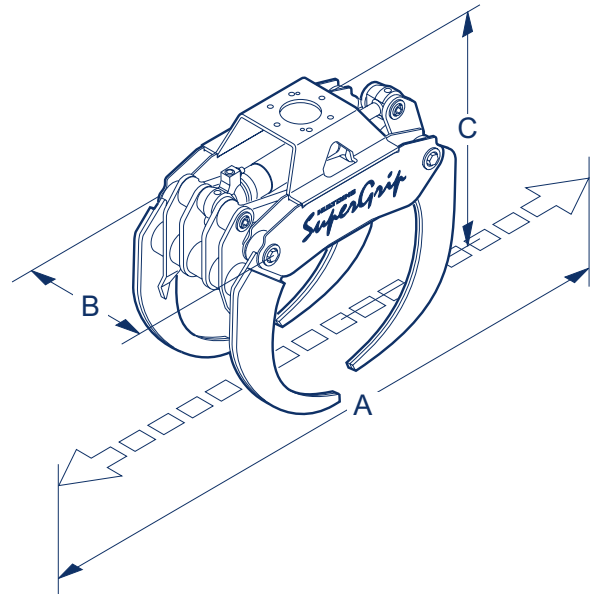

SuperGrip -R

Features

- For handling of slash and bioenergy wood (Note! Not suitable for stumps)
- Tapered sleeve pin design eliminates any joint motion
- 1000 hour greasing interval
- Strong cushioned cylinder reduces shock loads, designed for up to 25 MPa working pressure
- High strength steel and robotized welding ensures minimized down time

SuperGrip		260R	360R	420R	520R
Weight	kg	205	290	340	395
Max. load	kg	3 000	4 000	4 000	4 500
Gripping area, tip-tip	m ²	0.26	0.36	0.42	0.52
Gripping area, practical	m ²	0.35	0.45	0.52	0.62
Max. gripping width "A"	mm	1 536	1 855	2 072	2 317
Overall grapple width "B"	mm	430	510	510	514
Height, arms tip-tip "C"	mm	867	962	1 040	1 155
Max. height arms open	mm	760	800	848	886
Min. height arms closed	mm	550	627	649	747
Grapple jaw width	mm	384	452	460	456
Min. gripping diameter	mm	90	110	120	170
Gripping force, arms open, at 25 MPa	kN	10.9	18.5	19.4	20.9
Gripping force, arms tip-tip, at 25 MPa	kN	15.1	19.2	20.0	23.1
Opening time, at 50 l/min	s	0.9	1.6	2.1	2.2
Closing time, at 50 l/min	s	1.7	2.6	3.5	3.7
Max. operating pressure	MPa	25	25	25	25



Your productivity - our driving force

Hultdin System AB is a world leading manufacturer of components to mechanized forestry. With the productivity and profitability of our customers in focus we have over the years developed a wide product range consisting of Grapples, Saw Units, Grapple Saws, Damping Systems, and Active Load Space for forwarders and a Terrain Bridge for forestry machines.



HULTDINS SuperGrip™

Hultdins SuperGrip is the leading cut to length grapple in the forestry business. It is available in around 20 different models and is suited for all forwarders, trucks, different types of loaders or excavators.



HULTDINS SuperCut™

Hultdins SuperCut is the standard saw unit in most harvester heads over the world. It is also a very suitable saw unit for felling heads or advanced fire wood processors. Hultdins offers three main types of SuperCut saw units; SC standard, SC100 and SC300. The SuperCut provides unmatched saw performance in a wide range of applications.



HULTDINS SuperSaw™

Hultdins SuperSaw is a complete range of saw cassettes that are best mounted on the SuperGrip grapples. Together the SuperSaw and grapple form a high productive grapple saw package. A grapple saw is a very versatile tool that can be used for cross-cutting, loading, sorting merchandising and trimming.



HULTDINS Damping System

Hultdins Damping System is a passive damper that is connected to the lift or swing hydraulics of the crane. It dampens vibrations and reduces pressure peaks in the system which increases productivity and operator comfort as well as it prolongs the crane life.



HULTDINS Active Load Space

Hultdins Active Load Space (ALS), and the smaller thinning model (ALS-T), is a variable load space for forwarders. Widening of the bunks and variable load stakes in height adapt the load area to the density of the load. That way nominal load for the machine can always be reached regardless of wood quality, this increases productivity. The load space, which is floating on dampened hydraulics, saves both the machine and its operator from vibrations and physical stress. It can also be tilted, which increases machine manoeuvrability in tight areas, and makes it possible to reposition 30-50% of the load weight between the sides - a very valuable feature on soft ground conditions.



HULTDINS Terrain Bridge 500

HTB 500 (Hultdins Terrain Bridge 500) is a portable bridge for forestry machines. It is designed to facilitate the crossing of creeks and small streams. The bridge is carried on the forwarder load space and placed out with the crane. HTB 500 is light enough to be handled by the smallest forwarder crane, but strong enough to carry the heaviest forwarder with full load. Placing it over the creek only takes a couple of minutes. HTB 500 saves the environment as well as it shortens your forwarding distance and helps you from getting stuck.



Hultdin System AB, Skolgatan 12, SE-930 70 Malå, Sweden

Tel: 0953-418 00, Fax: 0953-418 01, E-mail: sales@hultdins.se

www.hultdins.se

Subject to change without prior notice